

Flange Insulation Kits



Manufacturers and distributors of sealing and jointing materials.



The Company

Novus Sealing manufactures and supplies a variety of high quality products designed for fluid sealing applications in the industrial and manufacturing sectors. Our company ethos is to provide honesty, reliability and a high level of service and dependability through all aspects of our business, adding value to our products and ensuring we sustain a competitive edge.

Over the years we have enhanced our technical facilities to develop more new products and provide guidance and training programmes for some of the world's largest chemical and petrochemical plants. We have a dedicated Research & Development team who ensure high quality technical support for all our products.

We constantly look to provide a balanced mix of quality sealing and jointing products with a professional friendly service.

Flange Insulation Kits

Novus Flange Insulation Kits are typically used on offshore installations, seawater environments, chemical installations, oil refinery pipelines where galvanic corrosion protection and electrical insulation is required.

Novus Flange Insulation Kits are designed for electrical flange insulation. They are used as an insulator between dissimilar metal flanges or to electrically isolate sections of pipework in cathodic protection systems, preventing the flow of electrostatic charge along the pipelines.

Kit Contents

Novus Sealing supply three standard types of Flange Insulation Kits; designed to suit either raised face, flat faced or ring grooved flange assemblies.

Each kit comprises electrically insulating flange gasket plus the following components :

One phenolic/mylar/GRE sleeve per bolt

Two laminated phenolic/mylar/GRE washers per bolt



Two plated steel washers per bolt

**Novus Flange Insulation Kit
Type F - Inner Bolt Circle (IBC) Gasket**

Inside Bolt Circle insulation kit utilises a central gasket which locates within the bolts.

The outer diameter of the gasket fits tightly into place assuring a well centered position.

The illustration clearly shows how the opposite flanges are totally insulated from each other.

For use on full face and raised face flanges.

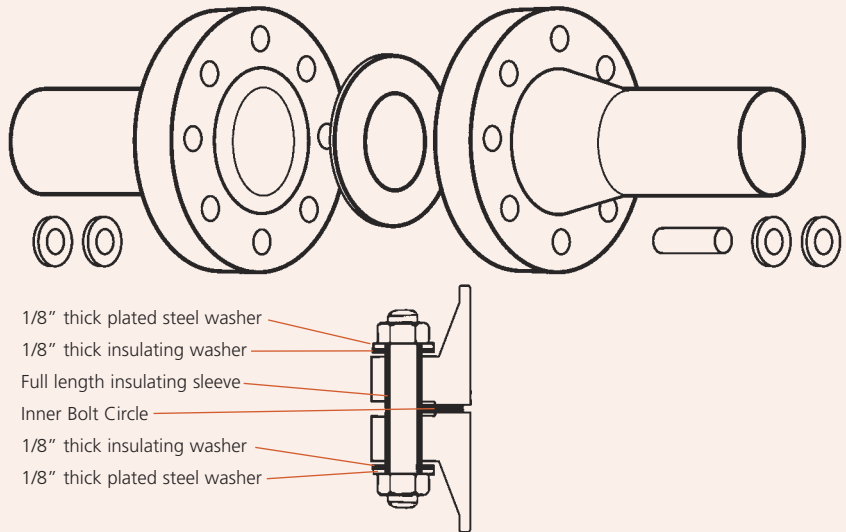

**Novus Flange Insulation Kit
Type E - Full Face**

Full Face insulation kits are suitable for flat face and raised face flanges.

This assembly minimises the ingress of conductive foreign matter between the portions of the flanges outside the raised faces and reduces the risk of bridging.

The illustration clearly shows how the opposite flanges are totally insulated from each other.

For use on full face and raised face flanges.

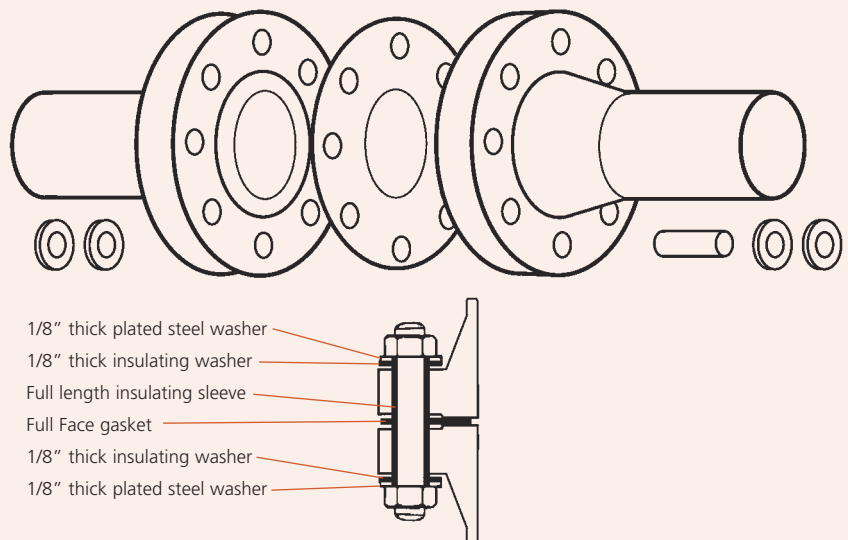

**Novus Flange Insulation Kit
Type D-RTJ**

Ring type joint insulation kits comprise of an oval insulating ring type joint gasket and are suitable for standard RTJ flanges.

The illustration clearly shows how the opposing flanges are totally insulated from each other.

For use on standard Ring Type Joint Flanges.

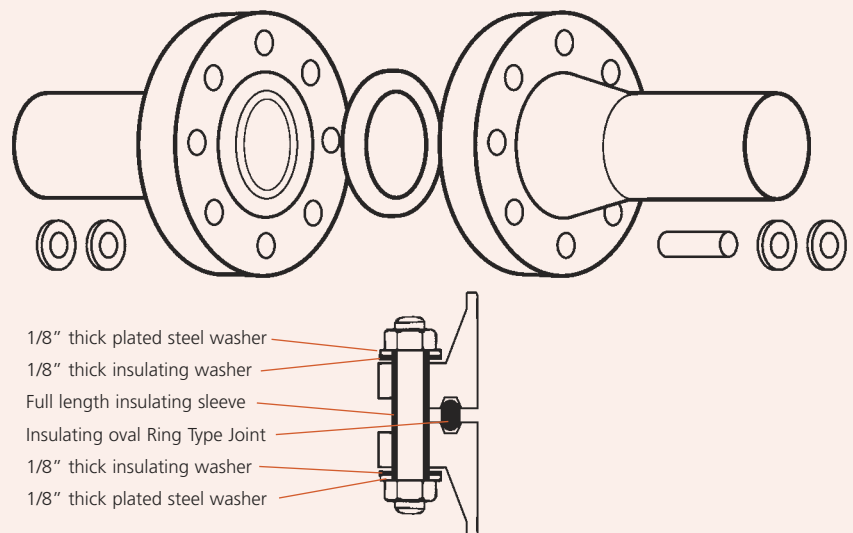

Insulating Gasket Materials

The following table presents our range of gasket materials suitable for insulating service.

Gasket Materials	Description	Dielectric Strength VPM	Maximum Continuous Operating Temperature. °C
Neoprene Faced Phenolic	Neoprene coated Phenolic	500	107
Novus 34	Premium grade fibre to BS7531 Grade X	120*	220*
Uniflon 50	Modified PTFE reinforced with glass microspheres	380*	260*
Uniflon 51	Modified PTFE reinforced with Silica	430*	260*
Uniflon 53	Modified PTFE reinforced with Barium Sulphate	450*	260*
Pikotek PGE	GRE Grade G10 & G11 core with O ring seals	750/500	140(G10) / 177 (G11)
Pikotek VCS	GRE laminated bonded to stainless steel core with spring energised seals Grade 10* and G11*	750/500	140 (G10) / 177 (G11)

*The operating temperature of these materials are related to their thickness. Thinner materials offer better temperature resistance than thicker grades.



Pikotek PGE is a low pressure service gasket designed to give operators an alternative to phenolic based insulating gaskets. With the range of sealing elements provided the PGE is rated for most if not all Hydrocarbon and water service applications. The unique offset design of the seal grooves creates a barrier, preventing any migration of the fluid and or gas. The PGE gasket provides a maintenance free, flange isolation and corrosion migration prevention solution.

Pikotek VCS has been designed to operate in **very critical service** applications. The gasket is suitable for use in Full Face, IBC and RTJ flanges. It has universally acclaimed excellent dielectric properties and superior sealing characteristics. The gasket is suitable for all pressure ratings including API 15,000 psi.

Pikotek is the registered trade mark of our associate suppliers for PGE and VCS specification materials.



Phenolic



Novus 34



Uniflon 50



Uniflon 51



Uniflon 53



Pikotek PGE



Pikotek VCS

Service Recommendations

The choice of the insulation gasket is dependant on the application criteria. In addition to temperature, the pressure rating must be taken into consideration before selecting the gasket material.

Seating Stress

To achieve an operationally reliable seal, the insulating gasket should be assembled within the seating stress parameters shown here.

***Note:** For Neoprene faced phenolic gaskets the bolts should be tightened using a torque wrench only. Hydraulic tensioning is not recommended for these gaskets. Experience has shown that a bolt stress of 30,000psi must not be exceeded for Neoprene faced phenolic gaskets.

Flange Surface Finish

It is imperative that the flange faces are clean. The recommended surface finish of the flanges is 3.2um (125 RMS) to 6.3um Ra (250 RMS).

Low Temperature Service

Insulations sets which employ elastomeric materials eg. Neoprene Faced Phenolic gaskets should not be used at temperatures below -40°C. For these temperatures we recommend the Uniflon range of gaskets or the Pikotec range fitted with a PTFE seal.

Contact our technical department for further information.

Seating Stress

Gasket Materials	Seating Stress (20°C)		
	Minimum (N/mm ²)	Optimum (N/mm ²)	Maximum (N/mm ²)
Neoprene Faced Phenolic	15	30	100
Novus 34	20*	40*	160*
Uniflon 50	15*	40*	135*
Uniflon 51	20*	40*	160*
Uniflon 53	20*	40*	160*
Pikotec PGE	30	50	160
Pikotec VCS	30	50	400

* The seating stresses are dependent on the gasket thickness. Thinner materials offer a lower minimum seating stress and a higher maximum seating stress than thicker materials.

How to order standard Neoprene Phenolic Insulation Kits

- Flange Insulation Type eg. **Type E**
- Size & Pressure rating or Ring Number eg. **Size 1" Class 300lbs R16**

Note: This can be abbreviated to -

Flange Insulation Kit Type E Size 1" Class 300lbs

If gasket material is different this will need to be specified in the event of an order ie:-

- Flange Insulation Type eg. **Type E**
- Size & Pressure rating or Ring Number eg. **Size 1" Class 300lbs**
- Gasket Material eg. **Uniflon 50**



Flange Insulation Kits - ASME Dimensions

Nominal Pipe Diameter	Gasket Inside Diameter	Class Rating LBS	GASKETS				Ring No. Type D	BOLTS			SLEEVES				WASHERS			
			Outside Dia. Type E (inches)	Outside Dia. Type E (mm)	Outside Dia. Type F (inches)	Outside Dia. Type F (mm)		Number of Bolts	Size of Bolts (inches)	Size of Bolts (mm)	Inside Dia. (inches)	Inside Dia. (mm)	Length (inches)	Length (mm)	Inside Dia. (inches)	Inside Dia. (mms)	Outside Dia. (inches)	Outside Dia. (mm)
1/2 15mm	1/2 15mm	150 300 4/600	3.1/2	88.90	1.11/16	42.86	-	4	1/2	12.70	1/2	12.70	1.1/16	26.99	9/16	14.29	1.1/8	28.58
			3.3/4	95.25	1.15/16	49.21	R11	4	1/2	12.70	1/2	12.70	1.5/16	33.34	9/16	14.29	1.1/8	28.58
			3.3/4	95.25	1.15/16	49.21	R11	4	1/2	12.70	1/2	12.70	1.13/16	46.04	9/16	14.29	1.1/8	28.58
			4.3/4	120.65	2.5/16	58.74	R12	4	3/4	19.05	3/4	19.05	2.7/16	61.91	13/16	20.64	1.9/16	39.69
			5.1/4	133.35	2.9/16	65.09	R13	4	3/4	19.05	3/4	19.05	3.1/16	77.79	13/16	20.64	1.9/16	39.69
3/4 20mm	3/4 20mm		3.7/8	98.43	2.1/16	52.39	-	4	1/2	12.70	1/2	12.70	1.3/16	30.16	9/16	14.29	1.1/8	28.58
			4.5/8	117.48	2.7/16	61.91	R13	4	5/8	15.88	5/8	15.88	1.7/16	36.51	11/16	17.46	1.5/16	33.34
			4.5/8	117.48	2.7/16	61.91	R13	4	5/8	15.88	5/8	15.88	1.15/16	49.21	11/16	17.46	1.5/16	33.34
			5.1/8	130.18	2.9/16	85.09	R14	4	3/4	19.05	3/4	19.05	2.11/16	68.26	13/16	20.64	1.9/16	39.69
			5.1/2	139.70	2.13/16	71.44	R16	4	3/4	19.05	3/4	19.05	3.3/16	80.96	13/16	20.64	1.9/16	39.69
1 25mm	1 25mm		4.1/4	107.95	2.7/16	61.91	R15	4	1/2	12.70	1/2	12.70	1.5/16	33.34	9/16	14.29	1.1/8	28.58
			4.7/8	123.83	2.11/16	68.26	R16	4	5/8	15.88	5/8	15.88	1.9/16	39.69	11/16	17.46	1.5/16	33.34
			4.7/8	123.83	2.11/16	68.26	R16	4	5/8	15.88	5/8	15.88	2.1/16	52.39	11/16	17.46	1.5/16	33.34
			5.7/8	149.23	2.15/16	74.61	R16	4	7/8	22.23	7/8	22.23	2.13/16	71.44	15/16	23.81	1.3/4	44.45
			6.1/4	158.75	3.3/16	80.96	R18	4	7/8	22.23	7/8	22.23	3.7/16	87.31	15/16	23.81	1.3/4	44.45
1.1/4 32mm	1.1/4 32mm		4.5/8	117.48	2.13/16	71.44	R17	4	1/2	12.70	1/2	12.70	1.7/16	36.51	9/16	14.29	1.1/8	28.58
			5.1/4	133.35	3.1/16	77.79	R18	4	5/8	15.88	5/8	15.88	1.11/16	42.86	11/16	17.46	1.5/16	33.34
			5.1/4	133.35	3.1/16	77.79	R18	4	5/8	15.88	5/8	15.88	2.5/16	58.74	11/16	17.46	1.5/16	33.34
			6.1/4	158.75	3.5/16	84.14	R18	4	7/8	22.23	7/8	22.23	2.15/16	74.61	15/16	23.81	1.3/4	44.45
			7.1/4	184.15	3.15/16	100.01	R21	4	1	25.40	1	25.40	3.11/16	93.66	1.1/16	26.99	2	50.80
1.1/2 40mm	1.1/2 40mm		5	127.00	3.3/16	80.96	R19	4	1/2	12.70	1/2	12.70	1.9/16	39.69	9/16	14.29	1.1/8	28.58
			6.1/8	155.58	3.9/16	90.49	R20	4	3/4	19.05	3/4	19.05	1.13/16	46.04	13/16	20.64	1.9/16	39.69
			6.1/8	155.58	3.9/16	90.49	R20	4	3/4	19.05	3/4	19.05	2.7/16	61.91	13/16	20.64	1.9/16	39.69
			7	177.80	3.11/16	93.66	R20	4	1	25.40	1	25.40	3.3/16	80.96	1.1/16	26.99	2	50.80
			8	203.20	4.7/16	112.71	R23	4	1.1/8	28.58	1.1/8	28.58	4.3/16	106.36	1.3/16	30.16	2.3/16	55.56
2 50mm	2 50mm		6	152.40	3.15/16	100.01	R22	4	5/8	15.88	5/8	15.88	1.11/16	42.86	11/16	17.46	1.5/16	33.34
			6.1/2	165.10	4.3/16	106.36	R23	8	5/8	15.88	5/8	15.88	1.15/16	49.21	11/16	17.46	1.5/16	33.34
			6.1/2	165.10	4.3/16	106.36	R23	8	5/8	15.88	5/8	15.88	2.11/16	68.26	11/16	17.46	1.5/16	33.34
			8.1/2	215.90	5.7/16	138.11	R24	8	7/8	22.23	7/8	22.23	3.11/16	93.66	15/16	23.81	1.3/4	44.45
			9.1/4	234.95	5.9/16	141.29	R26	8	1	25.40	1	25.40	4.11/16	119.06	1.1/16	26.99	2	50.80
2.1/2 65mm	2.1/2 65mm		7	177.80	4.11/16	119.06	R25	4	5/8	15.88	5/8	15.88	1.15/16	49.21	11/16	17.46	1.5/16	33.34
			7.1/2	190.50	4.15/16	125.41	R26	8	3/4	19.05	3/4	19.05	2.3/16	55.56	13/16	20.64	1.9/16	39.69
			7.1/2	190.50	4.15/16	125.41	R26	8	3/4	19.05	3/4	19.05	3.15/16	74.61	13/16	20.64	1.9/16	39.69
			9.5/8	244.48	6.5/16	160.34	R27	8	1	25.40	1	25.40	3.15/16	100.01	1.1/16	26.99	2	50.80
			10.1/2	266.70	6.7/16	163.51	R28	8	1.1/8	28.58	1.1/8	28.58	5.3/16	131.76	1.3/16	30.16	2.3/16	55.56
3 80mm	3 80mm		7.1/2	190.50	5.3/16	131.76	R29	4	5/8	15.88	5/8	15.88	2.1/16	52.39	11/16	17.46	1.5/16	33.34
			8.1/4	209.55	5.11/16	144.46	R31	8	3/4	19.05	3/4	19.05	2.7/16	61.91	13/16	20.64	1.9/16	39.69
			8.1/4	209.55	5.11/16	144.46	R32	8	3/4	19.05	3/4	19.05	3.3/16	80.96	13/16	20.64	1.9/16	39.69
			9.1/2	241.30	6.7/16	163.51	R31	8	7/8	22.23	7/8	22.23	3.11/16	93.66	15/16	23.81	1.3/4	44.45
			10.1/2	266.70	6.11/16	169.86	R35	8	1.1/8	28.58	1.1/8	28.58	4.7/16	112.71	1.3/16	30.16	2.3/16	55.56
3.1/2 90mm	3.1/2 90mm		12	304.80	7.9/16	192.09	R32	8	1.1/4	31.75	1.1/4	31.75	5.15/16	150.81	1.5/16	33.34	2.7/16	61.91
			8.1/2	215.90	6.3/16	157.16	R33	8	5/8	15.88	5/8	15.88	2.1/16	52.39	11/16	17.46	1.5/16	33.34
			9	228.60	6.5/16	160.34	R34	8	3/4	19.05	3/4	19.05	2.9/16	65.09	13/16	20.64	1.5/16	33.34
			9	228.60	6.3/16	157.16	R34	8	7/8	22.23	7/8	22.23	3.1/16	77.79	15/16	23.81	1.3/4	44.45
			9	228.60	6.11/16	169.86	R36	8	5/8	15.88	5/8	15.88	2.1/16	52.39	11/16	17.46	1.5/16	33.34
4 100mm	4 100mm		10	254.00	6.15/16	176.21	R37	8	3/4	19.05	3/4	19.05	2.11/16	68.26	13/16	20.64	1.9/16	39.69
			10	254.00	6.15/16	176.21	R37	8	7/8	22.23	7/8	22.23	3.7/16	87.31	15/16	23.81	1.3/4	44.45
			10.3/4	273.05	7.7/16	188.91	R37	8	7/8	22.23	7/8	22.23	3.11/16	93.66	15/16	23.81	1.3/4	44.45
			11.1/2	292.10	7.15/16	201.61	R37	8	1.1/8	28.58	1.1/8	28.58	4.13/16	122.24	1.3/16	30.16	2.3/16	55.56
			12.1/4	311.15	8.1/16	204.79	R39	8	1.1/4	31.75	1.1/4	31.75	4.15/16	125.41	1.5/16	33.34	2.7/16	61.91
5 125mm	5 125mm		14	355.60	9.1/16	230.19	R38	8	1.1/2	38.10	1.1/2	38.10	6.11/16	169.86	1.9/16	39.69	2.7/8	73.03
			10	254.00	7.9/16	192.09	R40	8	3/4	19.05	3/4	19.05	2.1/16	52.39	13/16	20.64	1.9/16	39.69
			11	279.40	8.5/16	211.14	R41	8	3/4	19.05	3/4	19.05	2.15/16	74.61	13/16	20.64	1.9/16	39.69
			11	279.40	8.1/16	204.79	R41	8	7/8	22.23	7/8	22.23	3.11/16	93.66	15/16	23.81	1.3/4	44.45
			11	279.40	9.5/16	236.54	R41	8	1	25.40	1	25.40	4.3/16	106.36	1.1/16	26.99	2	50.80
5 125mm	5 125mm		13.3/4	349.25	9.9/16	242.89	R41	8	1.1/4	31.75	1.1/4	31.75	4.11/16	119.06	1.5/16	33.34	2.7/16	61.91
			14.3/4	374.65	9.13/16	249.24	R44	8	1.1/2	38.10	1.1/2	38.10	6.7/16	163.51	1.9/16	39.69	2.7/8	73.03
			16.1/2	419.10	10.13/16	274.64	R42	8	1.3/4	44.45	1.3/4	44.45	7.15/16	201.61	1.13/16	46.04	3.5/16	84.14
			10	254.00	7.9/16	192.09	R40	8	3/4	19.05	3/4	19.05	2.1/16	52.39	13/16	20.64	1.9/16	39.69
			11	279.40	8.5/16	211.14	R41	8	3/4	19.05	3/4	19.05	2.15/16	74.61	13/16	20.64	1.9/16	39.69



Flange Insulation Kits - ASME Dimensions (Continued)

Nominal Pipe Diameter	Gasket Inside Diameter	Class Rating LBS	GASKETS				BOLTS			SLEEVES				WASHERS				
			Outside Dia. Type E (inches)	Outside Dia. Type E (mm)	Outside Dia. Type F (inches)	Outside Dia. Type F (mm)	Ring No. Type D	Number of Bolts	Size of Bolts (inches)	Size of Bolts (mm)	Inside Dia. (inches)	Inside Dia. (mm)	Length (inches)	Length (mm)	Inside Dia. (inches)	Inside Dia. (mms)	Outside Dia. (inches)	Outside Dia. (mm)
6 150mm	6 150mm	150	11	279.40	8.9/16	217.49	R43	8	3/4	19.05	3/4	19.05	2.3/16	55.56	13/16	20.64	1.9/16	39.69
		300	12.1/2	317.50	9.11/16	246.06	R45	12	3/4	19.05	3/4	19.05	3.1/16	77.79	13/16	20.64	1.9/16	39.69
		400	12.1/2	317.50	9.9/16	242.89	R45	12	7/8	22.23	7/8	22.23	3.5/16	84.14	15/16	23.81	1.3/4	44.45
		600	14	355.60	10.5/16	261.94	R45	12	1	25.40	1	25.40	4.7/16	112.71	1.1/16	29.63	2	50.80
		900	15	381.00	11.13/16	300.04	R45	12	1.1/8	28.58	1.1/8	28.58	5.1/16	128.59	1.3/16	30.16	2.3/16	55.56
		1500	15.1/2	393.70	10.15/16	277.81	R46	12	1.3/8	34.93	1.3/8	34.93	7.3/16	182.56	1.7/16	36.51	2.5/8	66.68
		2500	19	482.60	12.5/16	312.74	R47	8	2	50.80	2	50.80	9.3/16	233.36	2.1/16	52.39	2.3/4	69.85
8 200mm	8 200mm	150	13.1/2	342.90	10.13/16	274.64	R48	8	3/4	19.05	3/4	19.05	2.7/16	61.91	13/16	20.64	1.9/16	39.69
		300	15	381.00	11.15/16	303.21	R49	12	7/8	22.23	7/8	22.23	3.7/16	87.31	15/16	23.81	1.3/4	44.45
		400	15	381.00	11.13/16	300.04	R49	12	1	25.40	1	25.40	4.7/16	112.71	1.1/16	26.99	2	50.80
		600	16.1/2	419.10	12.7/16	315.91	R49	12	1.1/8	28.58	1.1/8	28.58	5.1/16	128.59	1.13/16	46.04	2.3/16	55.56
		900	18.1/2	469.90	13.15/16	354.01	R49	12	1.3/8	34.93	1.3/8	34.93	5.11/16	144.46	1.7/16	36.51	2.5/8	66.68
		1500	19	482.60	13.11/16	347.66	R50	12	1.5/8	41.28	1.5/8	41.28	7.15/16	201.61	1.11/16	42.86	3.1/16	77.79
		2500	21.3/4	552.45	16.1/16	407.99	R51	12	2	50.80	2	50.80	10.11/16	271.46	2.1/16	52.39	3.3/4	95.25
10 250mm	10 250mm	150	16	406.40	13.3/16	334.96	R52	12	7/8	22.23	7/8	22.23	2.9/16	65.09	15/16	23.81	1.3/4	44.45
		300	17.1/2	444.50	14.1/16	357.19	R53	16	1	25.40	1	25.40	3.15/16	100.01	1.1/16	26.99	2	50.80
		400	17.1/2	444.50	13.15/16	354.01	R53	16	1.1/8	28.58	1.1/8	28.58	4.15/16	125.41	1.3/16	30.16	2.3/16	55.56
		600	20	508.00	15.9/16	395.29	R53	16	1.1/4	31.75	1.1/4	31.75	5.11/16	144.46	1.5/16	33.34	2.7/16	61.91
		900	21.1/2	546.10	16.15/16	430.21	R53	16	1.3/8	34.93	1.3/8	34.93	6.3/16	157.16	1.7/16	36.51	2.5/8	66.68
		1500	23	584.20	16.15/16	430.21	R54	12	1.7/8	47.63	1.7/8	47.63	9.3/16	233.36	1.5/16	33.34	3.1/2	88.90
		2500	26.1/2	673.10	18.9/16	471.49	R55	12	2.1/2	63.50	2.1/2	63.50	13.11/16	347.66	2.9/16	65.09	4.5/8	117.48
12 300mm	12 300mm	150	19	482.60	15.15/16	404.81	R56	12	7/8	22.23	7/8	22.23	2.11/16	68.26	15/16	23.81	1.3/4	44.45
		300	20.1/2	520.70	16.7/16	417.51	R57	16	1.1/8	28.58	1.1/8	28.58	4.13/16	122.24	1.3/16	30.16	2.3/16	55.56
		400	20.1/2	520.70	16.5/16	414.34	R57	16	1.1/4	31.75	1.1/4	31.75	5.3/16	131.76	1.5/16	33.34	2.7/16	61.91
		600	22	558.80	17.13/16	452.44	R57	20	1.1/4	31.75	1.1/4	31.75	5.11/16	144.46	1.5/16	33.34	2.7/16	61.91
		900	24	609.60	19.7/16	493.71	R57	20	1.3/8	34.93	1.3/8	34.93	6.3/16	157.16	1.7/16	36.51	2.5/8	66.68
		1500	26.1/2	673.10	20.5/16	515.94	R58	16	2	50.80	2	50.80	10.7/16	265.11	2.1/16	52.39	3.3/4	95.25
		2500	30	762.00	21.7/16	544.51	R60	12	2.3/4	69.85	2.3/4	69.85	15.3/16	385.76	2.13/16	71.44	5.1/16	128.59
14 350mm	13.1/4 336.55mm	150	21	533.40	17.9/16	446.09	R59	12	1	25.40	1	25.40	2.15/16	74.61	1.7/16	36.51	2	50.80
		300	23	584.20	18.15/16	481.01	R61	20	1.1/8	28.58	1.1/8	28.58	4.7/16	112.71	1.3/16	30.16	2.3/16	55.56
		400	23	584.20	18.13/16	477.84	R61	20	1.1/4	31.75	1.1/4	31.75	5.7/16	138.11	1.5/16	33.34	2.7/16	61.91
		600	23.3/4	603.25	19.3/16	487.36	R61	20	1.3/8	34.93	1.3/8	34.93	6.3/16	157.16	1.7/16	36.51	2.5/8	66.68
		900	25.1/4	641.35	20.5/16	515.94	R62	20	1.1/2	38.10	1.1/2	38.10	7.7/16	188.91	1.9/16	39.69	2.7/8	73.03
		1500	29.1/2	749.30	22.9/16	573.09	R63	16	2.1/4	57.15	2.1/4	57.15	11.3/16	284.16	2.5/16	58.74	4.3/16	106.36
		16 400mm	15.14 387.35mm	150	23.1/2	596.90	20.1/16	509.59	R64	16	1	25.40	1	25.40	3.1/16	77.79	1.1/16	26.99
300	25.1/2			647.70	21.1/16	534.99	R64	20	1.1/4	31.75	1.1/4	31.75	4.11/16	119.06	1.7/16	36.51	2.7/16	61.90
400	25.1/2			647.70	20.5/16	515.94	R65	20	1.3/8	34.93	1.3/8	34.93	5.11/16	144.46	1.7/16	36.51	2.5/8	66.68
600	27			685.80	22.1/16	560.39	R65	20	1.1/2	38.10	1.1/2	38.10	6.11/16	169.86	1.9/16	39.69	2.7/8	73.03
900	27.3/4			704.85	22.7/16	569.91	R66	20	1.5/8	41.28	1.5/8	41.28	7.11/16	195.26	1.11/16	42.86	3.1/16	77.79
1500	32.1/2			825.50	25.1/16	636.59	R67	16	2.1/2	63.50	2.1/2	63.50	12.3/16	309.56	2.9/16	65.09	4.5/8	117.48
18 450mm	17.1/4 438.15mm			150	25	635.00	21.7/16	544.51	R68	16	1.1/8	28.58	1.1/8	28.58	3.5/16	84.14	1.3/16	30.16
		300	28	711.20	23.5/16	592.14	R69	24	1.1/4	31.75	1.1/4	31.75	4.15/16	125.41	1.5/16	33.34	2.7/16	61.91
		400	28	711.20	23.3/16	588.96	R69	24	1.3/8	34.93	1.3/8	34.93	5.15/16	150.81	1.7/16	36.51	2.5/8	66.68
		600	29.1/4	742.95	23.15/16	608.01	R69	20	1.5/8	41.28	1.5/8	41.28	7.3/16	182.56	1.11/16	42.86	3.1/16	77.79
		900	31	787.40	24.15/16	633.41	R70	20	1.7/8	47.63	1.7/8	47.63	8.11/16	220.66	1.15/16	49.21	3.1/2	88.90
		1500	36	914.40	27.9/16	700.09	R71	16	2.3/4	69.85	2.3/4	69.85	13.7/16	341.31	2.13/16	71.34	5.1/16	128.59
		20 500mm	19.1/4 488.95mm	150	27.1/2	698.50	23.11/16	601.66	R72	20	1.1/8	28.58	1.1/8	28.58	3.9/16	90.49	1.3/16	30.16
300	30.1/2			774.70	25.9/16	649.22	R73	24	1.1/4	31.75	1.1/4	31.75	5.3/16	131.76	1.5/16	33.34	2.7/16	61.91
400	30.1/2			774.70	25.5/16	642.94	R73	24	1.1/2	38.10	1.1/2	38.10	6.3/16	157.16	1.9/16	39.69	2.7/8	73.03
600	32			812.80	26.11/16	677.86	R73	24	1.5/8	41.28	1.5/8	41.28	7.11/16	195.26	1.11/16	42.86	3.1/16	77.79
900	33.3/4			857.25	27.5/16	693.74	R74	20	2	50.80	2	50.80	9.3/16	233.36	2.1/16	52.39	2.3/4	69.85
1500	38.3/4			984.25	29.9/16	750.89	R75	16	3	76.20	3	76.20	14.11/16	373.06	3.1/16	77.79	5.1/2	139.70
24 600mm	23.1/4 590.55mm			150	32	812.80	28.1/16	712.79	R76	20	1.1/4	31.75	1.1/4	31.75	3.15/16	100.01	1.5/16	33.34
		300	36	914.40	30.5/16	769.94	R77	24	1.1/2	38.10	1.1/2	38.10	5.11/16	144.46	1.9/16	39.69	2.7/8	73.03
		400	36	914.40	30.1/16	763.59	R77	24	1.3/4	44.45	1.3/4	44.45	6.11/16	169.86	1.13/16	46.04	3.5/16	84.14
		600	37	939.80	30.15/16	785.81	R77	24	1.7/8	47.63	1.7/8	47.63	8.11/16	220.66	1.15/16	49.21	3.1/2	88.90
		900	41	1041.40	32.13/16	833.44	R78	20	2.1/2	63.50	2.1/2	63.50	11.11/16	296.86	2.9/16	65.09	4.5/8	117.48
		1500	46	1168.40	35.5/16	896.94	R79	16	3.1/2	88.90	3.1/2	88.90	16.11/16	423.86	3.9/16	90.49	6.3/8	161.93

Note: Gasket inner dimension is based on schedule 40 pipes

W O R L D W I D E



Novus Sealing and our distributors are fully committed to ensuring our customers throughout the world receive the highest level of quality and technical support for our products and services. Our technical specialists can provide expertise on all issues associated with sealing performance.



Novus Sealing Limited, Hunsworth Lane, Cleckheaton, West Yorkshire, England BD19 4EJ

Tel: +44 (0)1274 878787 **Fax:** +44 (0)1274 862588 **www:** www.novussealing.com **e-mail:** mailbox@novussealing.com



Esclusività e Distribuzione in Italia:

SESAM VOLONTE' F.LLI S.R.L.
advanced gasket and industrial materials

20090 FIZZONASCO di Pieve Emanuele MI
Via Calabria 16
Tel. 02 90723571 r.a.
Fax 02 90781680
E-mail info@sesamsrl.com - www.sesamsrl.com