

Ring Type Joints



Manufacturers and distributors of sealing and jointing materials

Ring Type Joints

Novus Sealing is an independent company manufacturing and supplying a variety of high quality sealing products designed for flange applications in the industrial and manufacturing sectors. We have an extensive network of distributors worldwide, including Novus companies in Australia, China and South Africa ensuring that we can meet all of our customers global requirements.

Novus Sealing supply Ring Type Joints which are fully approved to API 6A Product Specification level 4, the highest quality rating, as well as ISO 9001: 2000 and ISO 14001.

Ring Type Joints are widely used by the Oil, Gas, Petrochemical and Offshore Industries in applications subject to high pressures and temperatures.

These joints are designed to concentrate the bolt load over a small area thus producing high seating stresses. As the ring type material should always be softer than the mating flanges, the high seating stress causes 'plastic-flow' of the ring joint in the flange faces creating the seal.



Ring Type Joints



Novus Sealing supplies a range of specialised Ring Type Joints for critical and non standard applications to suit the requirements of the petrochemical industry.

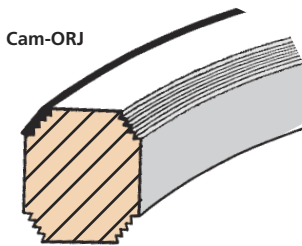

Cam-ORJ

The Cam-ORJ is a standard API 6A octagonal ring joint but with the four angled seating surfaces concentrically serrated and faced with oxidation inhibited graphite. The gasket offers the high sealing efficiency associated with the octagonal design but with the added benefit of being capable of sealing flanges with minor damage. Under compression the graphite flows into minor imperfections creating a tight seal.

The Cam-ORJ is available in a range of Alloy materials and in sizing to suit ASME B16.5 or API 6A flanges.

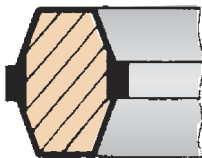
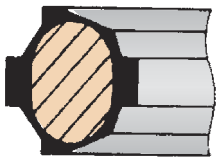

Novus model M8R and M9R Rubber Coated Ring Type Joints

This is an octagonal/oval section ring type joint generally soft iron or low carbon steel totally enclosed in a nitrile rubber coating. Widely used in pressure testing procedures, minimising any damage to the flange.

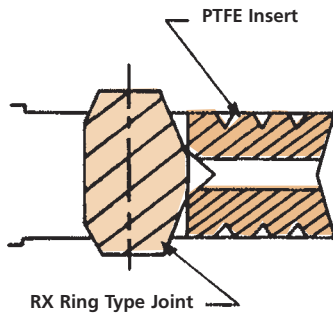

Novus model M12PI

Ring Type Joints with PTFE Inserts

M12 model RX Ring Type Joints can be supplied with PTFE inserts. Designed to reduce turbulent flow and eliminate ring joint and flange corrosion. The insert is specially designed with radially drilled holes ensuring the self-energising performance is not affected. The insert is located between the inside diameter of the ring joint and the bore of the flange. On assembly, the insert is captured between the flanges, filling the void between ring joint and flange bore.

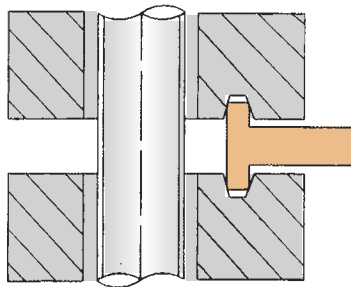

Blind Ring Type Joints

These specialised Ring Type Joints are designed and manufactured for the customer who has a requirement to blank off flanges and pipe work. The Joints are standard rings but with a machined metallic centre.

Blind Ring Type Joints can be supplied in a variety of materials.

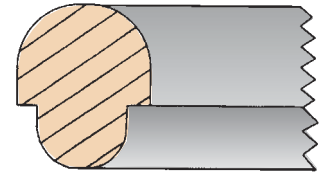

Combination Ring Type Joints

This Ring Type Joint consists of 2 different sizes having the same pitch diameter, used for sealing and flange joint where the mating flanges have different ring groove dimensions or profiles.

These Ring Type Joints can be produced with either octagonal or oval facings, however they are not manufactured in accordance with API specification.



Lens Rings

This is a contact seal for use in high pressure piping systems and in pressure vessel heads. Lens rings have a spherical surface that requires special matching of the flanges. Effective sealing is obtained at a relatively low bolt loads.

These ring type joints are manufactured in accordance with DIN 2696. For enquiries complete drawings must be supplied.



Delta Rings

This is a pressure actuated ring used primarily on pressure vessels and valve bonnets at pressures in excess of 5000 psi. Internal pressure forces the delta ring material to expand.

As with the Lens rings for enquiries and orders should be sent with complete drawings.

Ring Type Joint Profiles

Type R Ring Type Joints

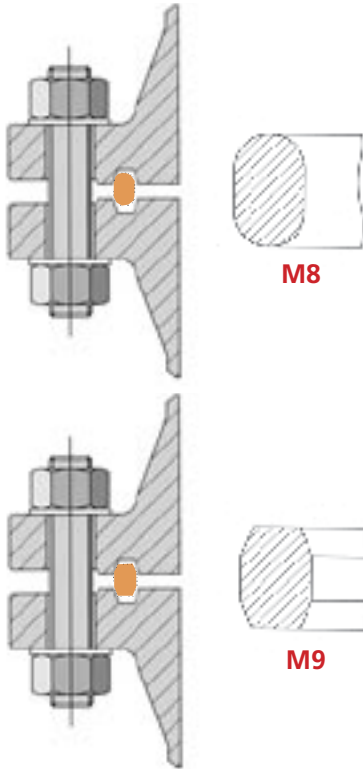

Novus models M8 and M9

M8 model R Oval section and M9 model R Octagonal section ring type joints are designed for flanges with standard ring type grooves. These standard shapes are used to seal pressures up to 5,000 psi in accordance with API 6A.

The Octagonal cross section has a higher sealing efficiency than the oval cross section and is therefore preferred. The oval section ring joints were originally designed for the now obsolete round bottom groove. Both the oval and the octagonal cross section are interchangeable on the flat bottom groove design.

Type BX Ring Type Joints

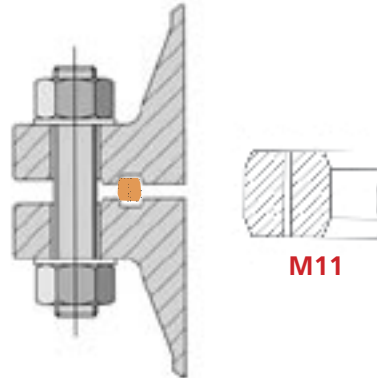

Novus model M11/M11S

M11 model BX Ring Type Joints are designed for pressures up to 20,000 psi, suitable only for use with API type BX flanges and grooves. The gasket has a square cross section with bevelled corners. The average diameter of the ring joint is slightly greater than that of the flange groove. This way, when the ring joint is seated, it stays pre-compressed by the outside diameter, creating high seating stress.

The M11S Model SBX Ring Type Joint is the same design as the BX Ring, however the suffix 'S' indicates that additional pressure equalisation holes have been drilled in accordance with API 17D for use on sub sea wellhead and christmas tree equipment.

Type RX Ring Type Joints

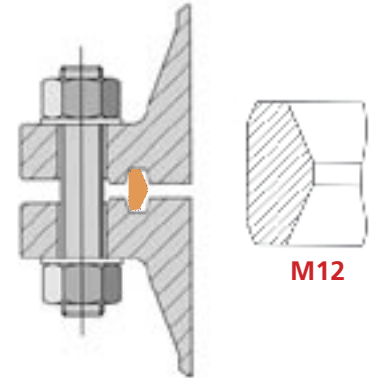

Novus model M12/M12S

M12 model RX Ring Type Joints are designed for pressures up to 5,000 psi.

A pressure activated ring joint, its shape is designed to use the fluid pressure to increase sealability. The outside sealing surface of the ring joint makes the initial contact with the flange. As the internal pressure rises the contact pressure between ring joint and flange also increases. This is sometimes referred to as a pressure activated ring joint. due to the shape of the gasket. High seating pressures are created increasing the sealability. This design characteristic makes the RX ring joint more resistant to vibrations, pressure surges and shocks that occur during oil well drilling.

M12S Model SBX Ring Type Joint is the same in design to the RX Ring, however, the suffix 'S' indicates that additional pressure equalisation holes have been drilled in accordance with API 17D for use on sub sea wellhead and christmas tree equipment.



Ring Type Joints



Service

We pride ourselves on providing our customers with a high quality product, supported by an outstanding, honest and reliable service.

We hold a comprehensive stock of most standard ring type joints

Quality

All Novus Ring Type Joints are manufactured with full traceability to API6A PSL 4. Each ring type joint has (etched on the non seating surface) the heat number, ring number, material identification and API licence number etc providing comprehensive information to our end user.

Novus Sealing continues to invest in quality and environmental systems and are fully accredited to both ISO 9001 and ISO 14001.

Technical

Over the years Novus have enhanced their technical facilities to develop more new products and provide guidance and training programmes for some of the world's largest chemical and petrochemical plants.

We have a dedicated Research & Development team including an experienced metallurgist. They ensure high quality technical support for our complete product portfolio.

Investment

Novus Sealing continue to invest heavily in UK manufacturing and our metallic gasket department has recently gone through an expansion and modernisation programme, which puts us at the forefront of the gasket manufacturing industry

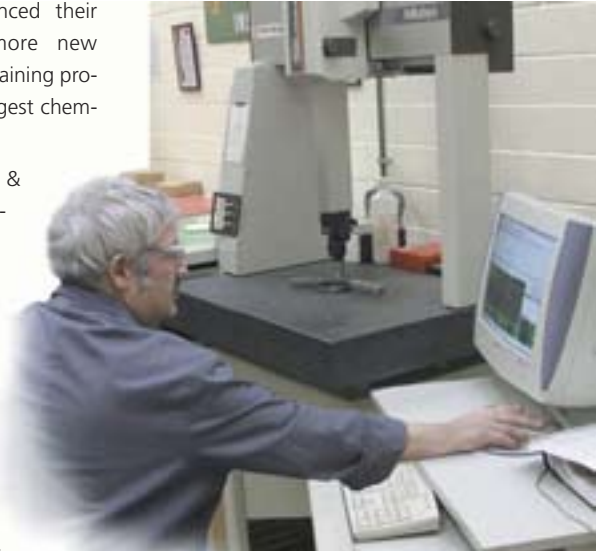

Accuracy and precision throughout the production process is rigorously checked.



Every Ring Type Joint is CNC machined for precision and consistent accuracy.



All Ring Type Joints are engraved on the nonseating surface with the ring number, heat number, material identification and the API licence number.



The production facility is work-flow designed for speed efficiency and ease of quality control.

Seating Stress

To achieve a reliable seal, the Ring Type Joint should be assembled within the following seating stress parameters:

Material	Identification	Seating Stress (20°C)		
		Minimum (N/mm ²)	Optimum (N/mm ²)	Maximum (N/mm ²)
Soft Iron	D	235	350	525
Low Carbon Steel	S	265	400	600
A182FS	FS	400	600	900
SS304	S304	335	500	750
SS316	S316	335	500	750
SS321	S321	335	500	750
SS347	S347	335	500	750

For other materials please contact our technical department

Flange Surface Finish

The Ring Type Joint and the sealing face of the groove must be free of indentations, score marks, tool and chatter marks.

The maximum flange surface finish for M8, M9, model R, M12 model RX is 1.6µm RA (63RMS).

The maximum flange surface finish for M11 model BX is 0.8µm RA (32RMS)

How to Order

A correct purchase order should contain the following information.

1. Ring Type Joint model eg. **M8 R Oval**
2. Ring number/size & pressure rating **R16/Class 1" 3/600lbs**
3. Material/identification **Soft Iron or D**
4. Flange Standard **ASME/ANSI B16.5**

Note: This can be abbreviated to **R16D Oval RTJ**



Ring Type Joints



Novus M12 Model RX Ring Type Joints

API Specification 6A Dimensional Data

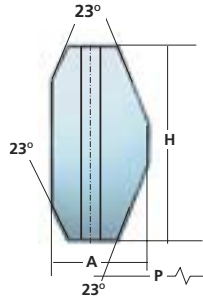

Tolerances (Inches)

A* (width of ring) +0.008, -0.000

H* (height of ring) +0.008, -0.000

OD (outside diameter of ring) +0.020, -0.000

23° (angle) + or - 0.5°

*A plus tolerance of 0.008 inches for width 'A' and height 'H' is permitted, provided the variation in width or height does not exceed 0.004 inches throughout the entire circumference.

Ring Number	Pressure Class Ratings (PSI)			Pitch Diameter of Ring P	Outside Diameter of Ring OD	Width of Ring A	Height of Ring H	Approx distance between made-up flanges	Approx Weight KG's
	API 6A								
	150	300/600	900						
	Nominal Pipe Sizes (Inches)								
RX20				68.26	76.20	8.74	19.05	9.7	0.24
RX23	2.1/16			82.55	93.27	11.91	25.40	11.9	0.53
RX24		2.1/16	2.1/16	95.25	105.97	11.91	25.40	11.9	0.62
RX25		3.1/8		101.60	109.54	8.74	19.05		0.36
RX26	2.9/16			101.60	111.91	11.91	25.40	11.9	0.66
RX27		2.9/16	2.9/16	107.95	118.26	11.91	25.40	11.9	0.70
RX31	3.1/8	3.1/8		123.85	134.54	11.91	25.40	11.9	0.80
RX35			3.1/8	136.53	147.24	11.91	25.40	11.9	0.89
RX37	4.1/16	4.1/16		149.23	159.94	11.91	25.40	11.9	0.97
RX39			4.1/16	161.93	172.64	11.91	25.40	11.9	1.05
RX41				180.98	191.69	11.91	25.40	11.9	1.18
RX44				193.68	204.39	11.91	25.40	11.9	1.26
RX45	7.1/16	7.1/16		211.15	221.84	11.91	25.40	11.9	1.37
RX46			7.1/16	211.15	222.25	13.49	28.58	11.9	1.67
RX47				228.60	245.26	19.84	41.28	18.3	3.91
RX49	9	9		269.88	280.59	11.91	25.40	11.9	1.76
RX50			9	269.88	283.36	16.66	31.75	11.9	2.89
RX53	11	11		323.85	334.57	11.91	25.40	11.9	2.11
RX54			11	323.85	337.34	16.66	31.75	11.9	3.47
RX57	13.5/8	13.5/8		381.00	391.72	11.91	25.40	11.9	2.48
RX63				419.10	441.73	27.00	50.80	21.30	12.03
RX65	16.3/4			469.90	480.62	11.91	25.40	11.9	3.06
RX66		16.3/4		469.90	483.39	16.66	31.75	11.9	5.04
RX69				533.40	544.12	11.91	25.40	11.9	3.48
RX70				533.40	550.06	19.84	41.28	18.3	9.18
RX73	21.1/4			584.20	596.11	13.49	31.75	15.0	4.66
RX74		20.3/4		584.20	600.86	19.84	41.28	18.3	10.06
RX82				57.15	67.87	11.91	25.40	11.9	0.37
RX84				63.50	74.22	11.91	25.40	11.9	0.41
RX85				79.38	90.09	13.49	25.40	9.7	0.53
RX86				90.50	103.58	15.09	28.58	9.7	0.82
RX87				100.03	113.11	15.09	28.58	9.7	0.91
RX88				123.83	139.29	17.48	31.75	9.7	1.48
RX89				114.30	129.77	18.26	31.75	9.7	1.37
RX90				155.58	174.63	19.84	44.45	18.3	3.12
RX91				260.35	286.94	30.16	45.24	19.1	7.80
RX99				234.95	245.67	11.91	25.40	11.9	1.53
RX201			1.3/8	46.05	51.46	5.74	11.30		0.06
RX205			1.13/16	57.15	62.31	5.56	11.10		0.08
RX210			2.9/16	88.90	97.64	9.53	19.05		0.35
RX215			4.1/16	130.18	140.89	11.91	25.40		0.78

Model RX are interchangeable with R Octagonal Ring Joints

A pressure balance hole of 1.5mm diameter is incorporated in RX82 through to RX91



Novus M11 Model BX Ring Type Joints

API Specification 6A Dimensional Data

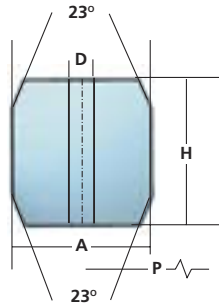

Tolerances (Inches)

A* (width of ring) +0.008, -0.000

D (hole size) + or - 0.02

H* (height of ring) + 0.008, - 0.000

OD (outside diameter of ring) + 0.000, - 0.006

23° (angle) + or - 0.25°

Ring Number	Pressure Class Ratings (PSI)						Outside Diameter of Ring OD	Height of Ring H	Width of Ring A	Hole Size D	Approx Weight KG's
	API 6A										
	2000	3000	5000	10000	15000	20000					
	Nominal Pipe Sizes (inches)										
BX150							72.19	9.30	9.30	1.60	0.13
BX151				1.13/16	1.13/16	1.13/16	76.40	9.63	9.63	1.60	0.15
BX152				2.1/16	2.1/16	2.1/16	84.68	10.24	10.24	1.60	0.19
BX153				2.9/16	2.9/16	2.9/16	100.94	11.38	11.38	1.60	0.28
BX154				3.1/16	3.1/16	3.1/16	116.84	12.40	12.40	1.60	0.39
BX155				4.1/16	4.1/16	4.1/16	147.96	14.22	14.22	1.60	0.66
BX156				7.1/16	7.1/16	7.1/16	237.92	18.62	18.62	3.20	1.84
BX157				9	9	9	294.46	20.98	20.98	3.20	2.92
BX158				11	11	11	352.04	23.14	23.14	3.20	4.26
BX159				13.5/8	13.5/8	13.5/8	426.72	25.70	25.70	3.20	6.42
BX160			13.5/8				402.59	23.83	13.74	3.20	3.03
BX161			16.3/4				491.41	28.07	16.21	3.20	5.14
BX162			16.3/4	16.3/4	16.3/4		475.49	14.22	14.22	1.60	2.26
BX163			18.3/4				556.16	30.10	17.37	3.20	6.70
BX164				18.3/4	18.3/4		570.56	30.10	24.59	3.20	9.73
BX165			21.1/4				624.71	32.03	18.49	3.20	8.54
BX166				21.3/4			640.03	32.03	26.14	3.20	12.38
BX167	26.3/4						759.36	35.87	13.11	1.60	8.14
BX168		26.3/4					765.25	35.87	16.05	1.60	10.13
BX169				5.1/8			173.51	15.85	12.93	1.60	0.79
BX170				9"	9"		218.03	14.22	14.22	1.60	1.00
BX171				11"	11"		267.44	14.22	14.22	1.60	1.24
BX172				13.5/8"	13.5/8"		333.07	14.22	14.22	1.60	1.56
BX303	30	30					852.75	37.95	16.97	1.60	12.66

BX Ring Joints can be used in API 6BX Flanges.

A pressure balance hole is incorporated in all BX Rings to equalise any pressure trapped in the flange.

Hardness of Ring Type Joint Materials

On installation, the material of the ring joint has to be softer than that of the flange to avoid damage.

This table provides comparative data of Ring Type Joint material hardness values.

Material (Trade Name)	Identification	DIN Specification	DIN Material No.	B.S.	AISI-ASTM UNS	Maximum Hardness		Temperature		Density
						Brinell HB	Rockwell B HRB	Min.	Max.	
Soft Iron	D	-	-	-	-	90	56	-40	500	7.85
Low Carbon Steel	S	R st 37.2	-	-	-	120	68	-40	500	7.85
F5	F5	5 Cr 0.5 mo	1.7362	-	A182F5	130	72	-40	650	7.83
SS 304	S304	X5Cr Ni 18	1.4301	304S15/16/13	304	160	83	-250	550	7.90
SS 304L	S304L	X2 Cr Ni 18.9	1.4306	304S11	304L	160	83	-250	550	7.90
SS 309	S309	X15 Cr Ni Si 20.12	1.4828	304S24	309	160	83	-100	1000	7.90
SS 316	S316	X5 Cr Ni Mo 18.10	1.4401	316S16	316	160	83	-100	550	7.90
SS 316L	S316L	X2 Cr Ni Mo 18.10	1.4404	316S11/13	316L	160	83	-100	550	7.90
SS 316Ti	S316Ti	X10 Cr Ni Mo Ti 18.10	1.4571	320S31	316Ti	160	83	-100	550	7.80
SS 321	S321	X10 Cr Ni Ti 18.9	1.4541	321S12/49/87	321	160	83	-250	550	7.90
SS 347	S347	X10 Cr Ni Nb 18.9	1.4550	347S31	347	160	83	-250	500	7.90
SS 410	S410	X6 Cr 13	1.4000	410S21	410	170	86	-20	850	7.80
254SMO	6Mo	X1Cr Ni Mo Cu N 20.18.7	1.4547	-	S31254	180	89	-100	500	8.00
Duplex	2205	X2 Cr Ni Mo N 22.5.3	14462	31853	S31803/32205	230 approx	99	-40	300	7.80
Super Duplex	2507	X2 Cr Ni Mo N 25.6.3	14410	-	S32750	230 approx	99	-40	300	7.80
Aluminium	AL 1050	A1 99.5	3.0255	1B	A91050	30	-	-250	300	2.71
Silver	Ag	-	-	-	-	28 (HV)	-	-250	750	10.50
Copper	Cu	SF-Cu	2.0090	C106	C12200	80 approx	-	-250	400	8.90
Brass	CuZn37	Cu Za 37 (M563)	20321	CZ108	C27200	60 approx	-	-100	350	8.50
Nickel 200	Ni 200	Ni 99.2	2.4066	3072-76 NA11	NO2200	110	62	-250	600	8.90
Monel 400	400	Ni Cu 30 Fe	2.4360	3072-76 NA13	NO4400	150	80	-125	600	8.80
Inconel 600	600	Ni Cu 15 Fe	2.4816	3072-76 NA14	NO6600	150	80	-100	950	8.40
Inconel 625	625	Ni Cr 22 Mo 9 Mb	2.4856	3072-76 NA 21	NO6625	150	80	- 50	450	8.44
Incoloy 800	800	X10 Ni Cr A1 Ti 3220	1.4876	3072-76 NA15	NO8800	150	80	-100	850	8.00
Incoloy 825	825	Ni Cr 21 Mo	2.4858	3072-76 NA16	NO8825	195	92	-100	450	8.14
Hastelloy B2	B2	Ni Mo 28	2.4617	-	NI0665	230	99	-200	450	9.20
Hastelloy C276	C276	Ni Mo 16 Cr 15 W	2.4819	-	NI0276	210	95	-200	450	8.90
Titanium	Ti2	Ti 99.8	3.7025	TA2	R50400	215 approx	96	-250	350	4.50

* Brinell hardness measured with 3000kg, and 10mm diameter hardened steel ball.

Softer materials i.e. copper & brass are measured with 500kgs and 10mm diameter hardened steel ball.

* Rockwell B hardness is measured with 100kg and 1.60mm diameter steel ball.

novus Ring Type Joints

Novus M8 Model R Oval and Novus M9 Model R Octagonal Ring Type Joints

API Specification 6A Dimensional Data

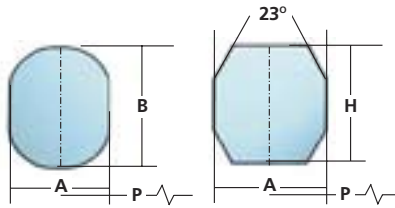

Tolerances (Inches)

A (width of ring) + or - 0.008

B,H (height of ring) + or - 0.020

P (average pitch diameter of ring) + or - 0.007

23° (angle) + or - 0.5°

Ring Number	Pressure Class Ratings									Pitch Diameter of Ring P	Width of Ring A	Height of Ring		Approx distance between made up flanges	Approx Weight KG's		
	ASME/ANSI B16.5			API 6A			ASME B16.47 Series A					Oval B	Octagonal H		Oval	Octagonal	
	150	300/600	900	1500	2000	3000	5000	150	300/600			900	Dimensions in Millimetres				
Nominal Pipe Sizes (inches)																	
R11		1/2									34.13	6.35	11.10	19.50		0.05	0.05
R12			1/2	1/2							39.69	7.95	14.30	12.70		0.10	0.09
R13		3/4			1/2						42.86	7.95	14.30	12.70		0.11	0.10
R14			3/4	3/4							44.45	7.95	14.30	12.70		0.11	0.11
R15	1										47.63	7.95	14.30	12.70		0.12	0.12
R16		1	1	1	3/4						50.80	7.95	14.30	12.70		0.13	0.13
R17	1.1/4										57.15	7.95	14.30	12.70		0.14	0.14
R18		1.1/4	1.1/4	1.1/4	1						60.33	7.95	14.30	12.70		0.15	0.15
R19	1.1/2										65.09	7.95	14.30	12.70		0.16	0.16
R20		1.1/2	1.1/2	1.1/2							68.28	7.95	14.30	12.70	4.1	0.17	0.17
R21					1.1/4						72.23	11.13	17.50	15.90		0.30	0.30
R22	2										82.55	7.95	14.30	12.70		0.21	0.19
R23		2			1.1/2	2.1/16					82.55	11.13	17.50	15.90	4.8	0.35	0.34
R24			2	2		2.1/16	2.1/16	2			95.25	11.13	17.50	15.90	4.8	0.40	0.39
R25	2.1/2										101.60	7.95	14.30	12.70		0.25	0.23
R26		2.1/2			2	2.9/16	2.9/16				101.60	11.13	17.50	15.90	4.8	0.43	0.42
R27			2.1/2	2.1/2			2.9/16	2.9/16			107.95	11.13	17.50	15.90	4.8	0.46	0.44
R28					2.1/2						111.13	12.70	19.10	17.50		0.58	0.57
R29	3										114.30	7.95	14.30	12.70		0.29	0.26
R30		3									117.48	11.13	17.50	15.90		0.50	0.48
R31		3	3			3.1/8	3.1/8				123.83	11.13	17.50	15.90	4.8	0.52	0.51
R32					3						127.00	12.70	19.10	17.50		0.66	0.65
R33	3.1/2										131.76	7.95	14.30	12.70		0.33	0.30
R34		3.1/2									131.76	11.13	17.50	15.90		0.56	0.54
R35				3				3.1/8			136.53	11.13	17.50	15.90	4.8	0.58	0.56
R36	4										149.23	7.95	14.30	12.70		0.37	0.34
R37		4	4			4.1/16	4.1/16				149.23	11.13	17.50	15.90	4.8	0.63	0.61
R38					4						157.16	15.88	22.40	20.60		1.18	1.15
R39				4				4.1/16			161.93	11.13	17.50	15.90	4.8	0.69	0.66
R40	5										171.45	7.95	14.30	12.70		0.43	0.40
R41		5	5								180.98	11.13	17.50	15.90	4.8	0.76	0.74
R42					5						190.50	19.05	25.40	23.90		1.94	1.91
R43	6										193.68	7.95	14.30	12.70		0.48	0.45
R44				5							193.68	11.13	17.50	15.90	4.8	0.82	0.79
R45		6	6			7.1/16	7.1/16				211.15	11.13	17.50	15.90	4.8	0.89	0.86
R46				6				7.1/16			211.15	12.70	19.10	17.50	4.8	1.10	1.08
R47					6						228.60	19.05	25.40	23.90	4.1	2.22	2.29
R48	8										247.65	7.95	14.30	12.70		0.62	0.57
R49		8	8			9	9				269.88	11.13	17.50	15.90	4.8	1.14	1.10
R50				8				9			269.88	15.88	22.40	20.60	4.1	2.03	1.99
R51					8						279.40	22.23	28.60	27.00		3.72	3.40
R52	10										304.80	7.95	14.30	12.70		0.76	0.70
R53		10	10			11	11				323.85	11.13	17.50	15.90	4.8	1.37	1.33
R54				10				11			323.85	15.88	22.40	20.60	4.1	2.43	2.39
R55					10						342.90	28.58	36.50	34.90		7.48	7.81

Notes: End flanges to API 6D and API 600 use ring joints for equivalent pipe size under ASME/ANSI B16.5 or ASME B16.47 series A
R30 is only suitable for lapped flanges.

Ring Type Joints



Novus M8 Model R Oval and Novus M9 Model R Octagonal Ring Type Joints

(continued)

API Specification 6A Dimensional Data

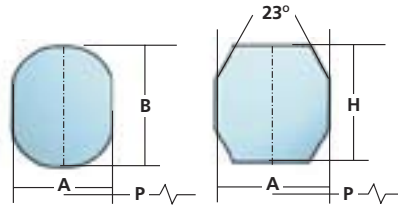

Tolerances (Inches)

A (width of ring) + or - 0.008

B,H (height of ring) + or - 0.020

P (average pitch diameter of ring) + or - 0.007

23° (angle) + or - 0.5°

Ring Number	Pressure Class Ratings											Pitch Diameter of Ring P	Width of Ring A	Height of Ring		Approx distance between made up flanges	Approx Weight KG's	
	ASME/ANSI B16.5					API 6A			ASME B16.47 Series A					Oval B	Octagonal H		Oval	Octagonal
	150	300/600	900	1500	2500	2000	3000	5000	150	300/600	900							
	Nominal Pipe Sizes (inches)													Dimensions in Millimetres				
R56	12					13.5/8	13.5/8					381.00	7.95	14.30	12.70		0.95	0.88
R57		12	12									381.00	11.13	17.50	15.90	4.8	1.61	1.56
R58				12								381.00	22.23	28.60	27.00		5.07	5.12
R59	14											396.88	7.95	14.30	12.70		0.99	0.92
R60					12							406.40	31.75	39.70	38.10		10.65	11.72
R61		14										419.10	11.13	17.50	15.90		1.77	1.72
R62			14									419.10	15.88	22.20	20.60		3.15	3.09
R63				14								419.10	25.40	33.30	31.80	5.6	7.45	7.52
R64	16											454.03	7.95	14.30	12.70		1.14	1.05
R65		16				16.3/4						469.90	11.13	17.50	15.90	4.8	1.98	1.92
R66			16				16					469.90	15.88	22.20	20.60	4.1	3.53	3.46
R67				16								469.90	28.58	36.50	34.90		10.25	10.71
R68	18											517.53	7.95	17.30	12.70		1.30	1.19
R69		18										533.40	11.13	17.50	15.90	4.8	2.27	2.20
R70			18				18					533.40	19.05	25.40	23.90	4.8	5.48	5.40
R71				18								533.40	28.58	36.50	34.90		11.75	12.27
R72	20											558.80	7.95	14.30	12.70		1.40	1.29
R73		20				21.3/4						584.20	12.70	19.10	17.50	3.3	3.03	2.99
R74			20				20.3/4					584.20	19.05	25.40	23.90	4.8	5.95	5.86
R75				20								584.20	31.76	39.70	38.10		15.31	16.20
R76	24											673.10	7.95	14.30	12.70		1.68	1.55
R77		24										692.15	15.88	22.40	20.60		5.20	5.10
R78			24									692.15	25.40	33.30	31.80		12.30	12.66
R79					24							692.15	34.93	44.50	41.30		22.40	22.98
R80												615.95	7.95		12.70			1.41
R81									22			635.00	14.29		19.10			3.92
R82										22		57.14	11.13		15.90	4.8		0.23
R84												63.50	11.13		15.90	4.8		0.26
R85												79.38	12.70		17.50	3.3		0.44
R86												90.50	15.88		20.60	4.1		0.66
R87												100.03	15.88		20.60	4.1		0.72
R88												122.83	19.05		23.90	4.8		1.24
R89												114.30	19.05		23.90	4.8		1.15
R90												155.58	22.23		26.90	4.8		2.06
R91												260.25	31.75		38.10	4.1		6.83
R92												228.60	11.13		17.50			0.92
R93																		
R94																		
R95																		
R96																		
R97																		
R98																		
R99																		
R100																		
R101																		
R102																		
R103																		
R104																		
R105																		

Notes: End flanges to API 6D and API 600 use ring joints for equivalent pipe size under ASME/ANSI B16.5 or ASME B16.47 series A

W O R L D W I D E



Novus Sealing and our distributors are fully committed to ensuring our customers throughout the world receive the highest level of quality and technical support for our products and services. Our technical specialists can provide expertise on all issues associated with sealing performance.



Novus Sealing Limited, Hunsworth Lane, Cleckheaton, West Yorkshire, England BD19 3UJ

Tel: +44 (0)1274 878787 **Fax:** +44 (0)1274 862588 **www:** www.novussealing.com **e-mail:** mailbox@novussealing.com



Certificate No. 18566
BS EN ISO 9001:2000



Certificate No. 18566
BS EN ISO 9001:2000



AS/NZS ISO 9001:2000
Lic: QEC 5296
SAM Global

Esclusività e Distribuzione in Italia:

SESAM VOLONTE' F.LLI S.R.L.
advanced gasket and industrial materials

20090 FIZZONASCO di Pieve Emanuele MI
Via Calabria 16
Tel. 02 90723571 r.a.
Fax 02 90781680
E-mail info@sesamsrl.com - www.sesamsrl.com